

ECS-3955M SERIES SMD CLOCK OSCILLATOR

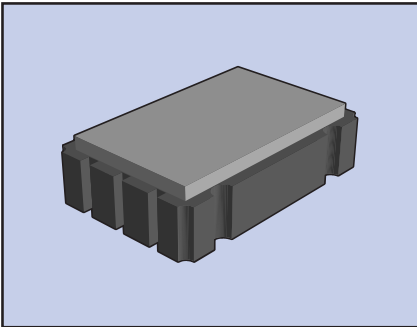

The ECS-3955M (5V) is a high capacitive load version of our miniature, crystal controlled, low current clock oscillator in an all ceramic SMD package. The low profile package is ideal for PC's, portable applications and PCMCIA cards.

FEATURES

- High capacitive load options
- Low power consumption
- Tri-State Function
- Seam welded package
- Tape & Reel (1,000 pcs STD)

PART NUMBERING GUIDE

	FREQUENCY (50.0 MHz)	STABILITY TOLERANCE (B=±50 PPM)
ECS-3955M	500	B

Sample Part Number: ECS-3955M-500-B

OPERATING CONDITIONS/ELECTRICAL CHARACTERISTICS

PARAMETERS	CONDITIONS	ECS-3955M (5V)			UNITS
		MIN	TYP	MAX	
FREQUENCY RANGE		1.800		70.0	MHz
TEMPERATURE RANGE	Operating	-10		+70	°C
	Storage	-55°		+125	°C
SUPPLY VOLTAGE		+4.5	+5.0	+5.5	V DC
FREQUENCY STABILITY*	Standard			±100	PPM
	Option (B)			±50	PPM
	Option (C)			±25	PPM
INPUT CURRENT	1.8 ~ 36.0 MHz			30	mA
	36.1 ~ 70.0 MHz			65	mA
OUTPUT SYMMETRY	@ 1/2 Vcc Level	40/60	50 ±4	60/40	%
RISE AND FALL TIMES				7	ns
OUTPUT VOLTAGE	VOL			Vcc x 0.1V	V DC
	VOH	Vcc x 0.9V			V DC
LOAD	HCMOS			50	pF
START-UP TIME	1.8 ~ 36.0 MHz			5	ms
	36.0 ~ 70.0 MHz			10	ms
OUTPUT CURRENT (IOL) (IOH)	VOL			16	mA
	VOH			-16	mA
ENABLE/DISABLE TIME				100	ns

* Inclusive of 25°C tolerance, operating temperature range, input voltage change, load change, aging shock and vibration.

** An internal pullup resistor from pin 1 to 4 allows active output if pin 1 is left open.

Note: A 0.01 µF bypass capacitor should be placed between VCC (Pin 4) and GND (Pin 2) to minimize power line noise.

PACKAGE DIMENSIONS (mm)

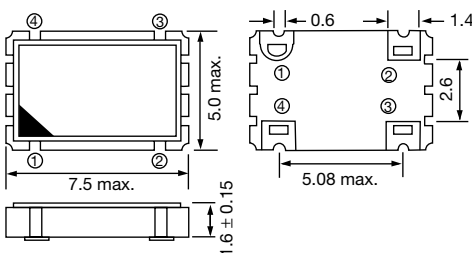

Figure 1) ECS-3955M Series Top, Side and Bottom Views

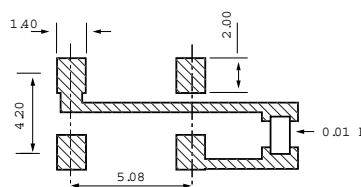

Figure 2) Land Pattern

PIN CONNECTIONS	
#1	TRI-STATE**
#2	GND
#3	OUTPUT
#4	Vcc

ECS-3955M Standby Control Voltage	
PIN #1 = OPEN	#3 = OSCILLATION
PIN #1 = +2.2V MIN	#3 = OSCILLATION
PIN #1 = 0.8V MAX	#3 = HIGH IMPEDANCE